

## Philco Radio & Television Corp.

**Model: 52-643**

**Chassis:**

**Year: Pre 1955**

**Power:**

**Circuit:**

**IF:**

**Tubes:**

**Bands:**

### Resources

[Riders Volume 23 - PHILCO 23-21](#)

[Riders Volume 23 - PHILCO 23-22](#)

[Riders Volume 23 - PHILCO 23-23](#)

[Riders Volume 23 - PHILCO 23-24](#)

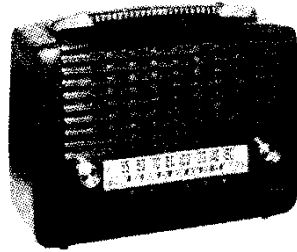

**MODEL 52-643**

**SPECIFICATIONS**

<b>CABINET</b> .....	Molded plastic, brown
<b>CIRCUIT</b> .....	Five-tube superheterodyne (plus selenium rectifier)
<b>FREQUENCY RANGE</b> .....	540—1620 kc.
<b>AUDIO OUTPUT</b> .....	160 milliwatts
<b>OPERATING VOLTAGES</b> .....	117 volts, a.c. or d.c.; or 9-volt "A" battery and 90-volt "B" battery
<b>POWER CONSUMPTION</b>	
A-c or d-c operation .....	15 watts
Battery operation .....	55 ma. at 9 volts, and 13 ma. at 90 volts
<b>AERIAL</b> .....	Magnecor high-impedance loop; provision for connecting external aerial
<b>INTERMEDIATE FREQUENCY</b> .....	265 kc.
<b>PHILCO TUBES (5)</b> .....	1T4 r-f ampl., 1R5 converter, 1U4 i-f ampl., 1U5 det.-a.v.c.—1st audio, 3V4 output
<b>BATTERY TYPE</b> .....	Philco P-363

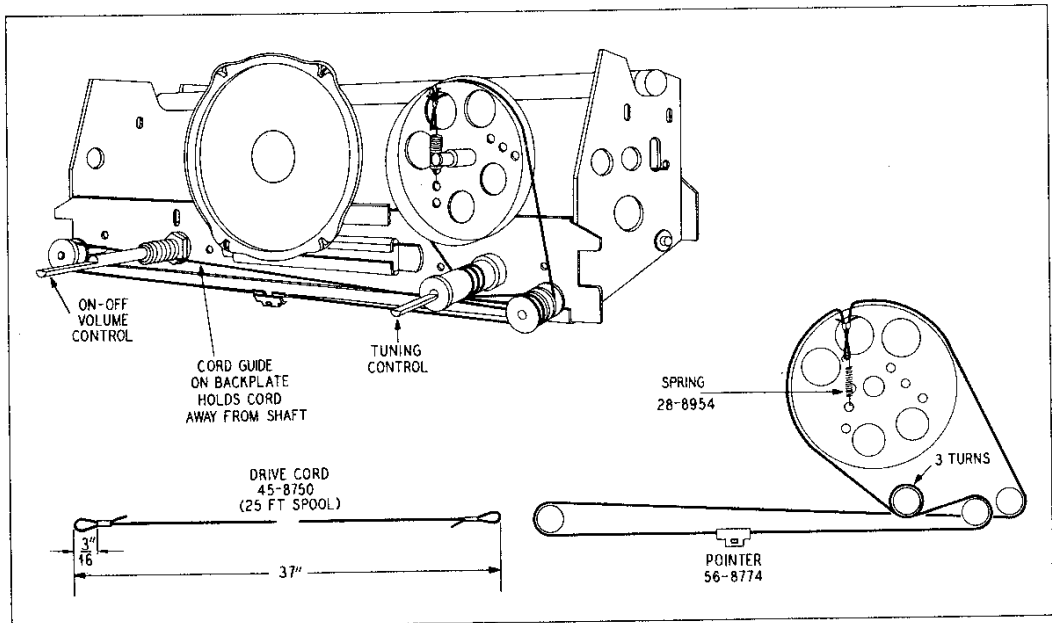

TP1-1711

**Figure 1. Drive-Cord-Installation Details**

### ALIGNMENT PROCEDURE

**POINTER**—Set pointer to coincide with first index mark from left side of dial backplate (looking at backplate).

**RADIO CONTROLS**—Set volume control to maximum.

**OUTPUT METER**—Connect across voice-coil terminals.

**SIGNAL GENERATOR**—Use modulated output.

**OUTPUT LEVEL**—During alignment, adjust signal-generator output to maintain output-meter indication below .5 volt.

**SPECIAL NOTE**—The orientation of the loop with respect to the chassis and battery is critical for correct tracking. During

alignment, with the cabinet back (containing the loop) lying flat on the bench, the chassis should be laid on its back in approximately its normal relation to the loop, with a 1/4"-thick wooden board separating the loop and chassis. The battery should also be placed as close as possible to its normal position with respect to the chassis and loop.

**CRITICAL LEAD DRESS**—To secure proper padding capacity, the green lead from pin 6 of the 1R5 tube to Z1 must be dressed over wiring panel, away from chassis, and the green lead from Z1 to the tuning condenser must be dressed away from chassis.

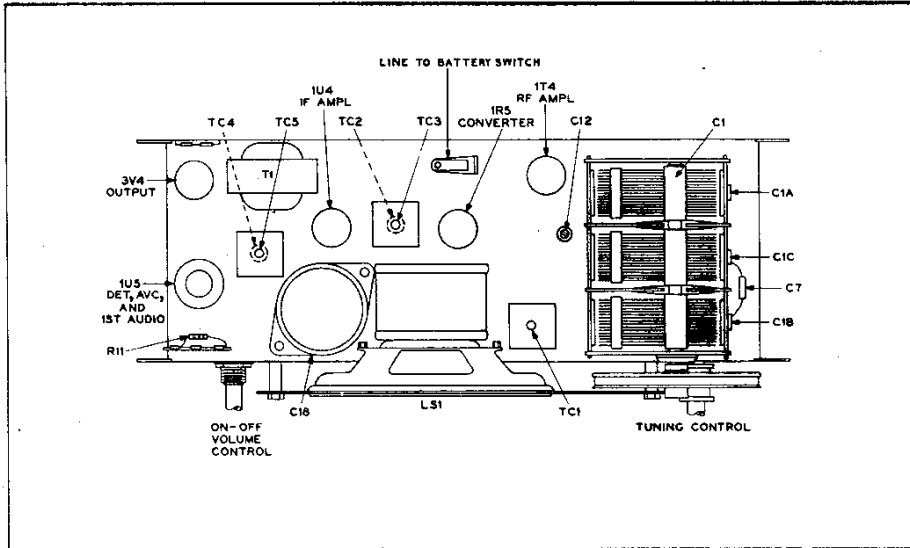

Figure 2. Top View, Showing Trimmer Locations

TP1-1712

### ALIGNMENT CHART

STEP	SIGNAL GENERATOR		RADIO		ADJUST
	CONNECTION TO RADIO	DIAL SETTING	DIAL SETTING	SPECIAL INSTRUCTIONS	
1	Through a .1- $\mu$ f. condenser to pin 6 of the 1R5 converter.	265 kc.	1620 kc. (gang fully open)	Adjust in order given, for maximum output.	TC5—2nd i-f sec. TC4—2nd i-f pri. TC2—1st i-f pri. TC3—1st i-f sec.
2	Radiating loop. See note below.	1620 kc.	1620 kc. (gang fully open)	Adjust for maximum output. If low-frequency dial tracking is far off, make adjustments in steps 3 and 4 before making this adjustment.	C1C—osc. shunt
3	Same as step 2.	580 kc.	580 kc.	Adjust for maximum output while rocking tuning control.	C13—osc. series
4	Same as step 2.	580 kc.	580 kc.	Adjust for maximum output. This adjustment should not be made unless dial tracking is off, or sensitivity is low at low-frequency end (580 kc.).	TC1—r-r sec.
5	Same as step 2.	1500 kc.	1500 kc. (index mark at right)	Adjust, in order given, for maximum output.	C1B—r-f trimmer C1A—aerial trimmer
6	Repeat steps 3 and 5 until no further improvement is obtained.				

**RADIATING LOOP:** Make up a six-to-eight-turn, 6-inch-diameter loop using insulated wire; connect to signal-generator leads and place near radio loop.

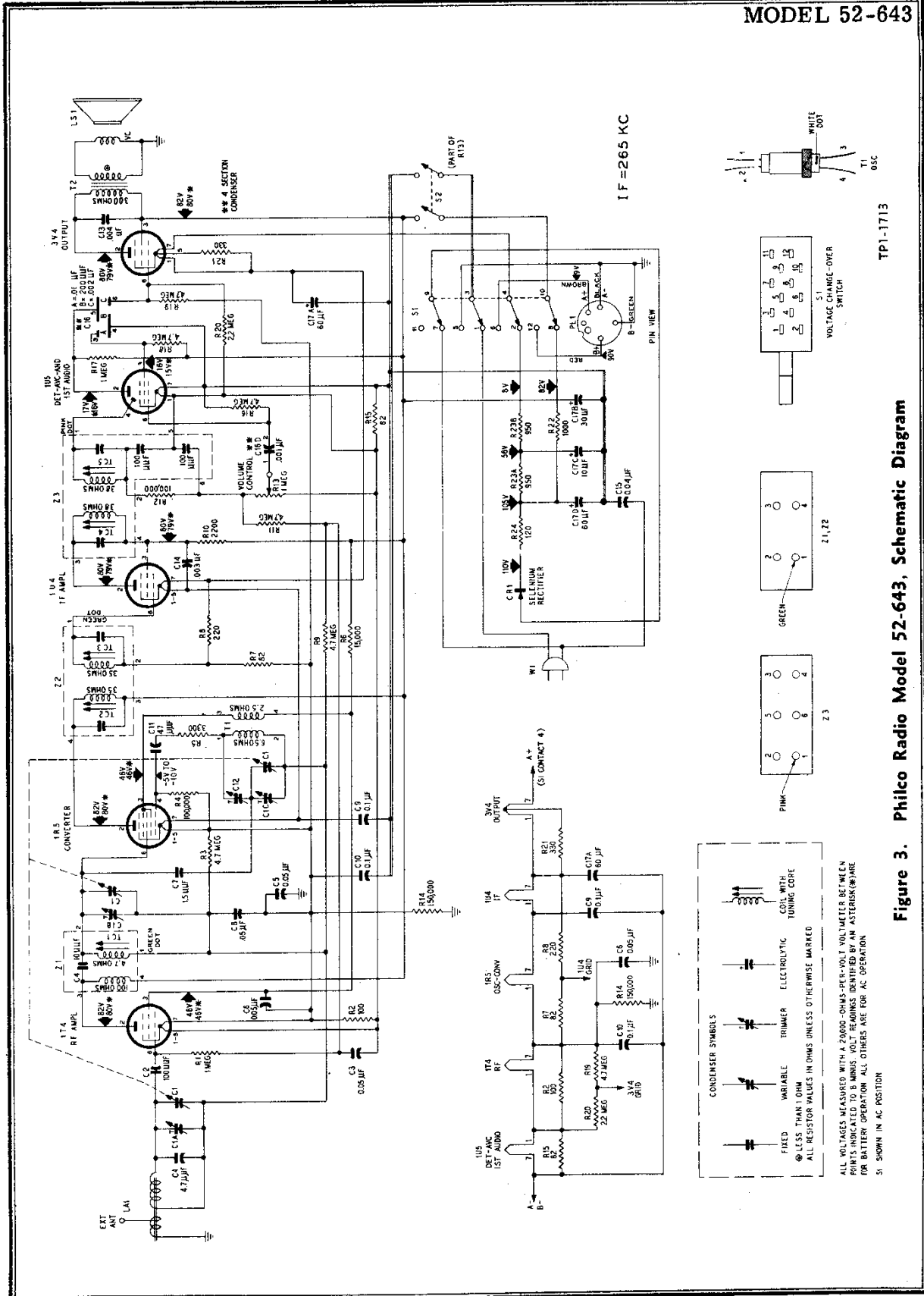

Figure 3. Philco Radio Model 52-643, Schematic Diagram

©John F. Rider

PARTS LIST

NOTE: Part numbers identified by an asterisk (\*) are general replacement items. These numbers may not be identical with those on factory parts; also, the electrical values of some replacement items may differ from the values indicated in the schematic diagram and parts list. The values substituted in any case are so chosen that the operation of the radio will be either unchanged or improved. When ordering replacements, use only the "Service Part No."

Reference Symbol	Description	Service Part No.
C1	Condenser, tuning gang, 3-section	31-2747-2
C1A	Condenser, antenna trimmer	Part of C1
C1B	Condenser, r-f trimmer	Part of C1
C1C	Condenser, osc. trimmer	Part of C1
C2	Condenser, d-c blocking, 100 $\mu$ f.	62-110009001*
C3	Condenser, bias filter, .05 $\mu$ f.	61-0122*
C4	Condenser, fixed trimmer, 4.7 $\mu$ f.	30-1230
C5	Condenser, filament by-pass, .05 $\mu$ f.	61-0122*
C6	Condenser, screen by-pass, .05 $\mu$ f.	61-0122*
C7	Condenser, neutralization, 1.5 $\mu$ f.	30-1221-3
C8	Condenser, a-v-c filter, .05 $\mu$ f.	61-0122*
C9	Condenser, filament by-pass, .1 $\mu$ f.	61-0113*
C10	Condenser, filament by-pass, .1 $\mu$ f.	61-0113*
C11	Condenser, d-c blocking, 47 $\mu$ f.	60-00475417*
C12	Condenser, osc. series padder, 600 to 800 $\mu$ f.	31-6473-16
C13	Condenser, tone compensation, .004 $\mu$ f.	61-0179*
C14	Condenser, screen neutralizing, .003 $\mu$ f.	61-0109*
C15	Condenser, line by-pass, .04 $\mu$ f.	45-3500-2*
C16	Condenser, ceramic, 4-section	30-1237
C16A	Condenser, screen by-pass, .01 $\mu$ f.	Part of C16
C16B	Condenser, by-pass, 200 $\mu$ f.	Part of C16
C16C	Condenser, d-c blocking, .002 $\mu$ f.	Part of C16
C16D	Condenser, d-c blocking, .001 $\mu$ f.	Part of C16
C17	Condenser, electrolytic, 4-section	30-2568-26
C17A	Condenser, filament by-pass, 60 $\mu$ f.	Part of C17
C17B	Condenser, filter, 30 $\mu$ f.	Part of C17
C17C	Condenser, filter, 10 $\mu$ f.	Part of C17
C17D	Condenser, filter, 60 $\mu$ f.	Part of C17
CR1	Selenium rectifier	34-8003*
LA1	Coil, antenna	32-4455-4
LS1	Speaker, 5-inch	36-1625
PL1	Plug and cable, battery	41-3712-5
R1	Resistor, grid return, 1 megohm	66-5108340*
R2	Resistor, current limiting, 100 ohms	66-1108340*
R3	Resistor, grid return, 4.7 megohms	66-5478340*
R4	Resistor, grid return, 100,000 ohms	66-4108340*
R5	Resistor, oscillator coupling, 3300 ohms	66-2338340*
R6	Resistor, dropping, 15,000 ohms	66-3158340*
R7	Resistor, grid return, 82 ohms	66-0828340*

Reference Symbol	Description	Service Part No.
R8	Resistor, grid return, 220 ohms	66-1228340*
R9	Resistor, a-v-c filter, 4.7 megohms	66-5478340*
R10	Resistor, neutralization, 2200 ohms	66-2228340*
R11	Resistor, a-v-c filter, 4.7 megohms	66-5478340*
R12	Resistor, i-f filter, 100,000 ohms	66-4108340*
R13	Resistor, VOLUME control, 1 megohm	33-5566-11
R14	Resistor, leakage, 150,000 ohms	66-4158340*
R15	Resistor, current limiting, 82 ohms	66-0828340*
R16	Resistor, grid return, 4.7 megohms	66-5478340*
R17	Resistor, plate load, 1 megohm	66-5108340*
R18	Resistor, screen dropping, 4.7 megohms	66-5478340*
R19	Resistor, grid return, 4.7 megohms	66-5478340*
R20	Resistor, grid return, 2.2 megohms	66-5228340*
R21	Resistor, current limiting, 330 ohms	66-1338340*
R22	Resistor, filter, 1000 ohms	66-2108340*
R23	Resistor, wire wound, 2-section	33-3431-7
R23A	Resistor, filament dropping, 950 ohms	Part of R23
R23B	Resistor, filament dropping, 950 ohms	Part of R23
R24	Resistor, wire wound, current limiting, 120 ohms	33-1334-14
S1	Switch, change-over	42-1899
S2	Switch, on-off	Part of R13
T1	Transformer, oscillator	32-4263-2
T2	Transformer, output	32-8528
W1	Line cord	L2183
Z1	Transformer, r-f	32-4399A
Z2	Transformer, 1st i-f	32-4160-2A
Z3	Transformer, 2nd i-f	32-4240-6A

MISCELLANEOUS

Description	Service Part No.
Cabinet complete	10883
Back	54-4903
Clip (2), back	56-3807-3
Handle assembly	76-6970
Scale	54-5127
Dial backplate assembly	76-7042
Backplate	56-9190FCP
Drive cord, 25-ft. spool	45-8750*
Pointer	56-8774
Spring, drive cord	28-8954
Shaft-and-pulley assembly	76-3671-4
Bushing	27-9437
Clip (1)	56-7057FA3
Knob (2)	54-4773-1
Mount (3), rubber	27-4596
Spring, retaining	57-1468FA3
Shield, 1U5 tube	56-5629FA3
Socket (4)	27-6209
Socket (1), 1U5 tube	27-6203-22
	54-4909
	56-9583

Handle end cover, plastic .....  
 Handle mounting bracket, metal .....

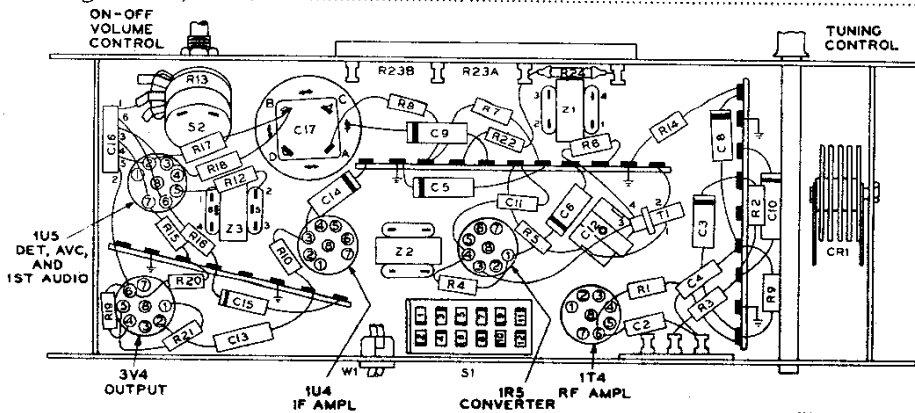

Figure 4. Bottom View, Showing Symbolized Chassis